



Burden Carrier

ELECTRIC SEATED TRACTOR

2,200-6,600LBS

EPS

Arbeit Series



UPT25D

Arbeit means Work.

The Stärke Arbeit includes electric power steering, German engineering and design aspects which power over the competition in strength, versatility and usability. The Arbeit was built for burden. As an electric burden carrier, the Arbeit understands that it was made to work, and because of its impressive cargo and towing capacities, it can move people and product easily throughout your warehouse, manufacturing plant, factory or facility.

FEATURES

Load Capacity

- 2,200 - 6,600 lbs

Towing Capacity

- 6,000 - 10,000 lbs

Battery

- Normal capacity K5
- chargers sold separately

Controls

- Curtis fully programmable
- Electric power steering
- High-performance multi-function meter displays: battery power, accumulative working hour, fault code etc.

Wheels

- Pneumatic and solid rubber available

Frame

- Compact design, small turning radius is ideal for operation in narrow aisles
- Two person

Powertrain/Electrical

- Drive wheel replacement and maintenance is simple and convenient
- DC drive motor
- 4.5 HP motor

Options

- Cabin on BD10-15 models



UPT10S



Optional of cabin

Why Choose a Stärke Arbeit over a competitor?

Burden Carrier Series	Stärke Arbeit	Cushman – Titan Series	Motrec – MC Series
Load Capacity	2,200 – 6,600 lbs	1,600 – 3,000 lbs	1,000 – 6,000 lbs

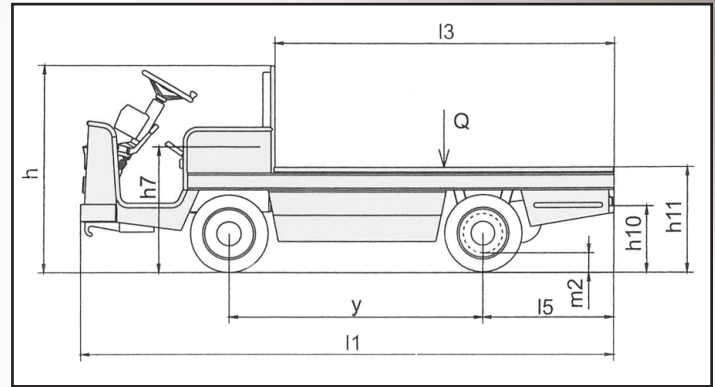
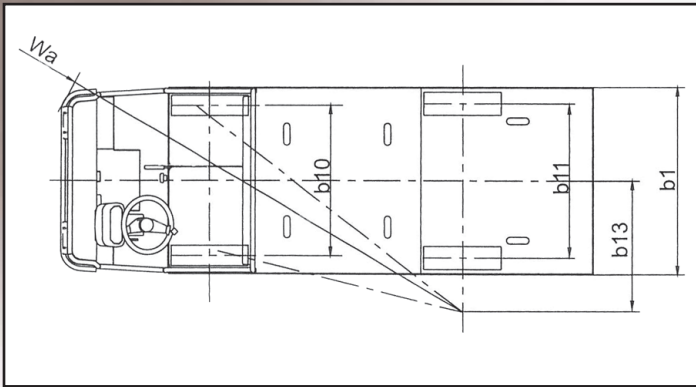

Arbeit Burden Carriers			UPT10S	UPT15S	UPT20D	UPT25D	UPT30D
Load Capacity	Q (lbs)		2,200	3,300	4,400	5,500	6,600
Towing Capacity	Q (lbs)		6,000	6,000	6,000	6,000	10,000
Wheelbase	y (in)		63.0	63.0	63.0	59.41	72.8
Axle loading, laden front/rear	lbs		1344/3020	1875/3815	2429/5161	2145/6215	3652/6798
Axle loading, unladen front/rear	lbs		1000/1170	1150/1235	1478/1703	1298/1562	1903/1947
Tires			-	-	pneumatic	solid	pneumatic
Tires Size	Front	(in)	15 x 4.5 - 8	15 x 4.5 - 8	6.0-9-10pr	16x5x10.5	6.0-9-10pr
	Rear	(in)	15 x 4.5 - 8	4.00 - 8	6.5-10-10pr	18x5x12.125	6.5-10-10pr
Tread	Front	b10 (in)	-	49.8"	42.5	36.2	42.5
	Rear	b11 (in)	34"	48"	42.1	36.4	48.4
Seat Height/stand height	h7 (in)		32.9	32.9	31.5	30.3	31.5
Coupling height	h10 (in)		102	110	197	157	217
Loading height, unladen	h11 (in)		18.1	18.9	29.5	24.4	30.7
Length of loading surface	l3 (in)		48.0	48.0	78.7	78.7	88.2
Overhang	l5 (in)		26.6	26.6	24.8	30.1	24.8
Overall Length	l1 (in)		97.8	97.8	126.0	124.0	135.4
Width of loading surface	b9 (in)		39.4	39.4	49.2	43.3	55.1
Overall width	b1/b2 (in)		41.5	39.4	49.2	43.3	55.1
Ground Clearance	Center of Wheelbase	m2 (in)	3.9	4.3	6.3	3.5	6.3
Turning Radius	Wa (in)		78.7	78.7	126.0	118.1	133.9
Internal turning radius	b13 (in)		78.7	78.7	55.1	40.9	59.1
Travel Speed	Laden/Unladen	mph	7.5/8.1	6.2/8.1	6.8/8.1	5.9/7.5	6.8/8.1
Gradeability	% / ft		10 / 49	10 / 49	10 / 65	10 / 65	10 / 65
Service Brake			Hydraulic	Hydraulic	Hydraulic	Hydraulic	Hydraulic
Battery Voltage, normal capacity K5	v/AH		48/240	48/270	48/330	48/250	48/395
Battery Weight	lbs		570	880	946	946	946
Battery Compartment Size	in		32.4x16.7x22.8	32.4x16.7x22.8	29.5x17.1x20.3	29.5x17.1x15.7	29.5x17.1x20.3
Battery Dimension	l/w/h	in	32.0x16.4x21.1	32.8x16.4x22.4	29.1x16.8x19.9	29.1x16.8x15.4	29.1x16.8x19.9
Service Weight with Battery	lbs		2156	2376	3190	2860	3850