

FEATURES

Capacity

- 2,000 lbs

Weight

- with battery 4796 lbs

Travel Speed

- 4.0 mph

Battery

- 24V / 400AH

Tires/Wheels

- Front: Pneumatic
- Back: polyurethane
- Vertical drive wheel offers easy maintenance

Powertrain/Electrical

- AC brushless motor eliminates wearable parts and minimizes maintenance costs
- Quality German engineered drive axle
- Less heat production
- Side unload battery for battery removal / exchange
- Emergency power cut off
- Rear wheel drive
- Easily maintained controller and steering potentiometer
- Standard headlight, brake & turn signals, and strobe light

Braking & Efficiency

- Wet disc brakes eliminate costly brake maintenance & repairs
- Regenerative braking minimizes wear on brakes and maximizes run time

Controls

- ZAPI fully programmable control system
- Hydraulic Steering
- Control lever position is ergonomically designed to reduce driver fatigue
- Low & high gear ratios for grade vs. level applications
- High performance multi-function instrumentation with LED light and display functions
- Back-up alarm
- Integrated light switch and forward/reverse shifter
- Parking brake



Revolutionize your factory, warehouse or indoor worksite with the ability to go from one end of your facility to the other, and deliver materials right to the production line or workstation, without weight, height or width restrictions.

Application:

Perfect for indoor applications where size matters; the compact Mini Forklift has an impressive turning radius and is also suitable for construction projects where a light-weight portable lift is required. The Mini works in retail settings too.

FBT10XA

Frame

- A wider German engineered mast, allowing for better visibility
- Length 62"
- Width 39.8"
- Height 83.7"
- Turning radius 50.8"
- Easily accessible cab
- Adjustable steering wheel and seat
- Overhead guard
- Seatbelt
- Excellent ramp/grade performance
- Low center of gravity offers increased stability

Options

- Customizable fork lengths and widths
- Lifting heights
- 2 and 3 stage masts with or without free lift, up to 196"
- Truckers mast available
- Side shift optional

Other

- Meets or exceeds ANSI B56.1 and CAN/CSA B335 Standards



Rev 02-2015

The Stärke 3-wheel Mini Forklift is your compact, narrow aisle workhorse that loves tight spaces.

Replace your multiple light-weight electric pallet trucks, stackers, reach trucks and forklifts with one unit that can do it all, while affording the same easy operation you'll find in a standard forklift.

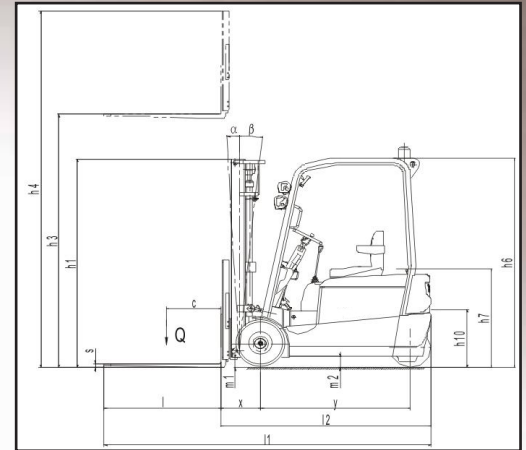
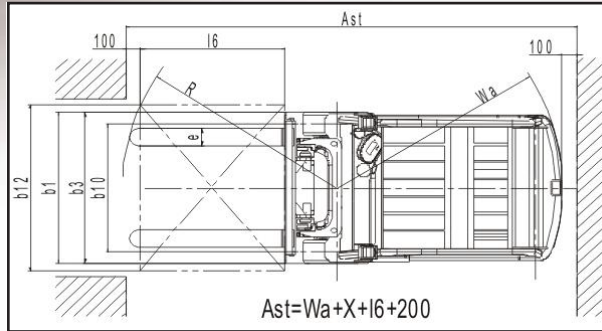

| | | FBT10XA | |
|------------------------|--|----------------|-------------------------|
| Characteristics | Load capacity | (Q) LBS | 2000 |
| | Drive / Operation type | Type | Rear Wheel Drive/Seated |
| | Load centre distance | (c) IN | 24 |
| | Wheel number, front/rear (x = driving wheel) | # | 2/1x |
| | Tread, front | (b10) IN | 35.1 |
| | Tread, rear | (b11) IN | 0.0 |
| | Wheels | Front Type | pneumatic |
| | Wheels | Rear Type | solid |
| Dimensions | Wheel dimension, front | | 16x6x10½ |
| | Wheel dimension, rear | | 280x100/PU |
| | Wheelbase | (y) IN | 42.5 |
| | Max. lift height | (h3) IN | 118.1 - 196.9 |
| | Coupling height | (h10) IN | 18.9 |
| | Overhead guard height (cabin) | (h6) IN | 77.4 |
| | Seat/stand height | (h7) IN | 33.5 |
| | Free Lift Height | (h2) IN | option |
| | Ground Clearance | (m2) IN | 3.3 |
| | Overall length without forks | (l2) IN | 62.0 |
| | Overall width | (b1) IN | 39.8 |
| | Fork carriage width | (b3) IN | 35.4 |
| | Fork dimension | (s/e/l) IN | 1.4 x 3.9 x 37.4* |
| | Aisle width, with pallet 39"x47" crosswise | (Ast) IN | 124.0 |
| | Aisle width, with pallet 32"x47" lengthwise | (Ast) IN | 128.0 |
| Performance | Turning radius | (Wa) IN | 50.8 |
| | Battery weight | LBS | 726.0 |
| | Service weight (with battery) | LBS | 4796 |
| | Traveling speed, laden/unladen | MPH | 4.0 / 4.0 |
| Driving System | Lifting speed, laden/unladen | IN/S | 5.9 / 7.1 |
| | Lowering speed, laden/ unladen | IN/S | 7.9 / 15.7 |
| Driving System | Max. gradeability, laden/unladen | % | 10 / 15 |
| | Battery voltage/rated capacity | v/Ah | 24 / 400 |
| | Driving motor power | HP | 3.0 |
| | Lifting motor power | HP | 3.0 |
| | Control System | Type | ZAPI |



MAST OPTIONS:

2 Stage

118"

138"

3 Stage

157"

177"

189"

196"

• Sideshift optional



Wet Disc Brakes



Multi-Function Display



Side Load Battery

* Custom fork lengths and widths available.

** All factory specifications are subject to change without notice.

